

straight_push_pull_plug_for_bend_relief

size: 3, IP6K8 / IP6K9K, keying: c, number_of_contacts: 18, solder_cup, contact_type: pins, Signal



Basic information

Part number	S13YCR-P18XJG0-0000
Category	connector
Type of connector	plug
Assembly situation	straight
Size	3

Contact insert description

Transmission type	Signal
Number of contacts	18
Contact type	pins
Contact diameter	0.9 mm
Termination type	solder_cup
Termination diameter	0.85 mm
Wire cross section AWG	AWG 22

Technical information

Nominal current single contact	10 A	IEC 60512-5-2:2002 (DIN EN 60512-5-2:2003)
Max. current insert	5	VDE 0298-4:2003
Test voltage	1.35 kV AC	EIA-364-20F:2019-02

Cable description

Cable outlet	overmolding
Min. cable diameter	6
Max. cable diameter	11.5

Mechanical and environmental data

Locking principle	push_pull
Keying	c
Mating cycles	5000
IP class	IP6K8 / IP6K9K
Max. operating temperature	125 °C
Min. operating temperature	-51 °C
Weight	19.98 g

ip_protection_class_refers_to_mated_condition

Material and surface treatments

Material	aluminum_with_ruthenium_finish
Insulator material	peek
Contact material	cu_alloy_with_gold_finish

DIMENSIONS:

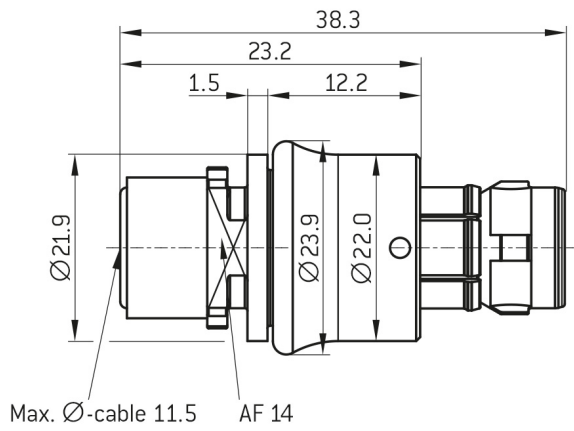

CODING:C

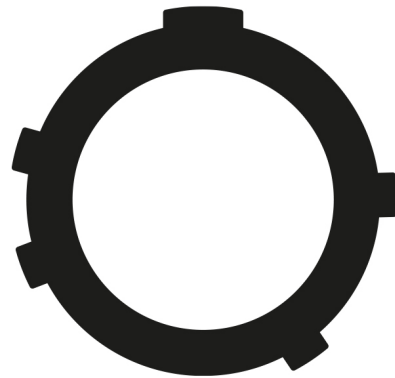

POSITIONS: 18 positions

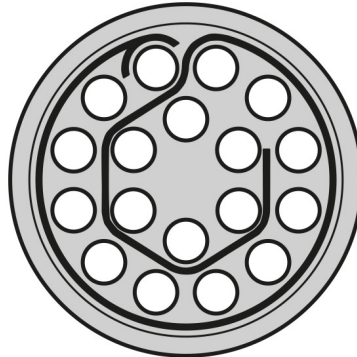

Further technical information and downloads

[Assembly Instruction](#)